

REVISIONS				
ZONE	REV.	DESCRIPTION	DATE	APPROVED
	A	INITIAL RELEASE	9/26/17	S. KELLER
	B	BRACKET WITH WINGS	4/26/2021	S. BLODGETT
	C	ADD RANGER AND ORDER CODE	1/11/2022	S. BLODGETT

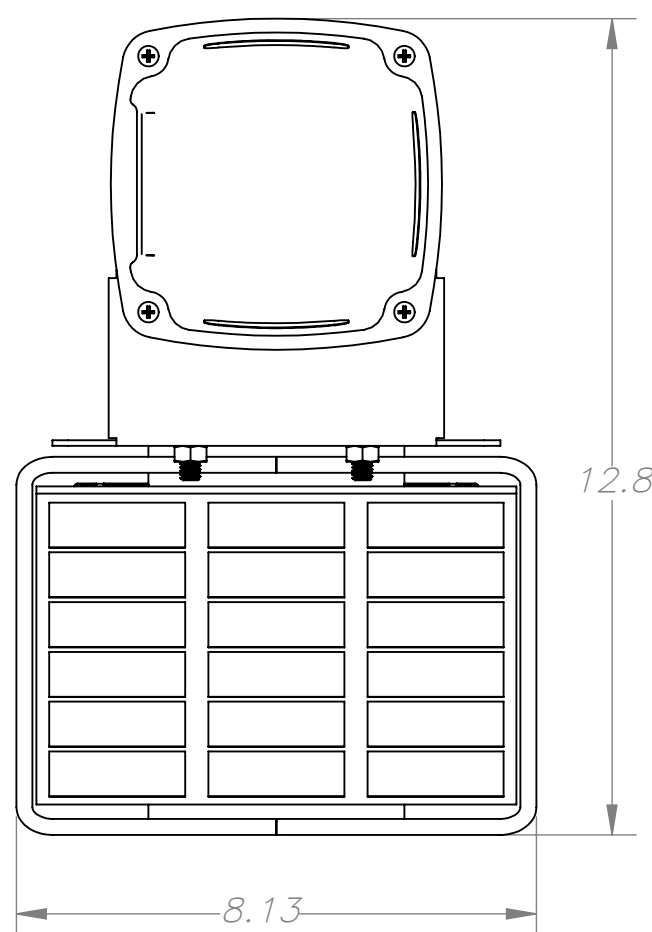
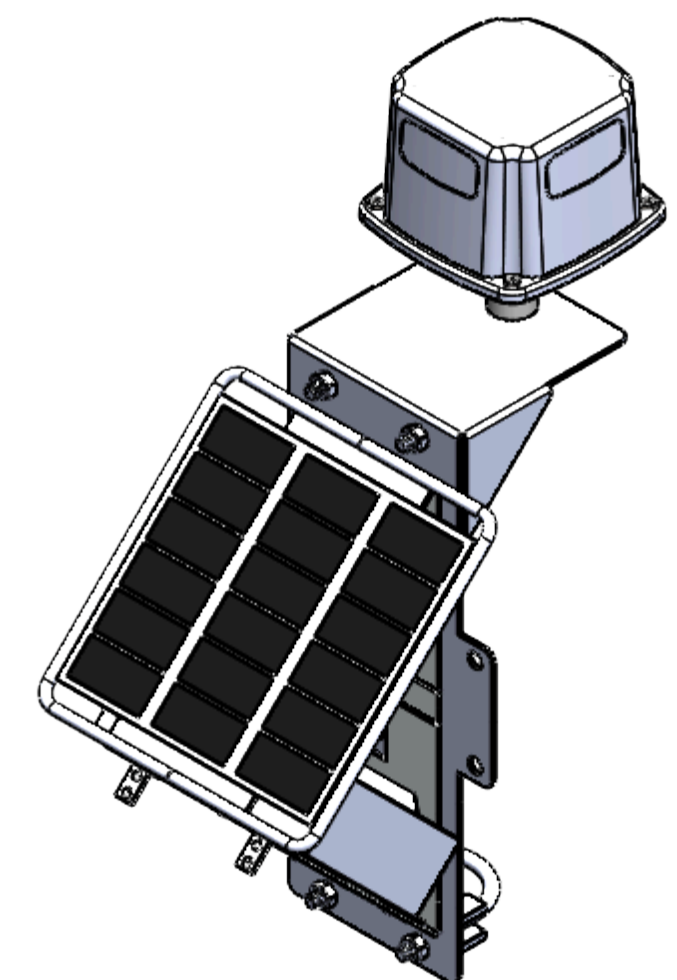
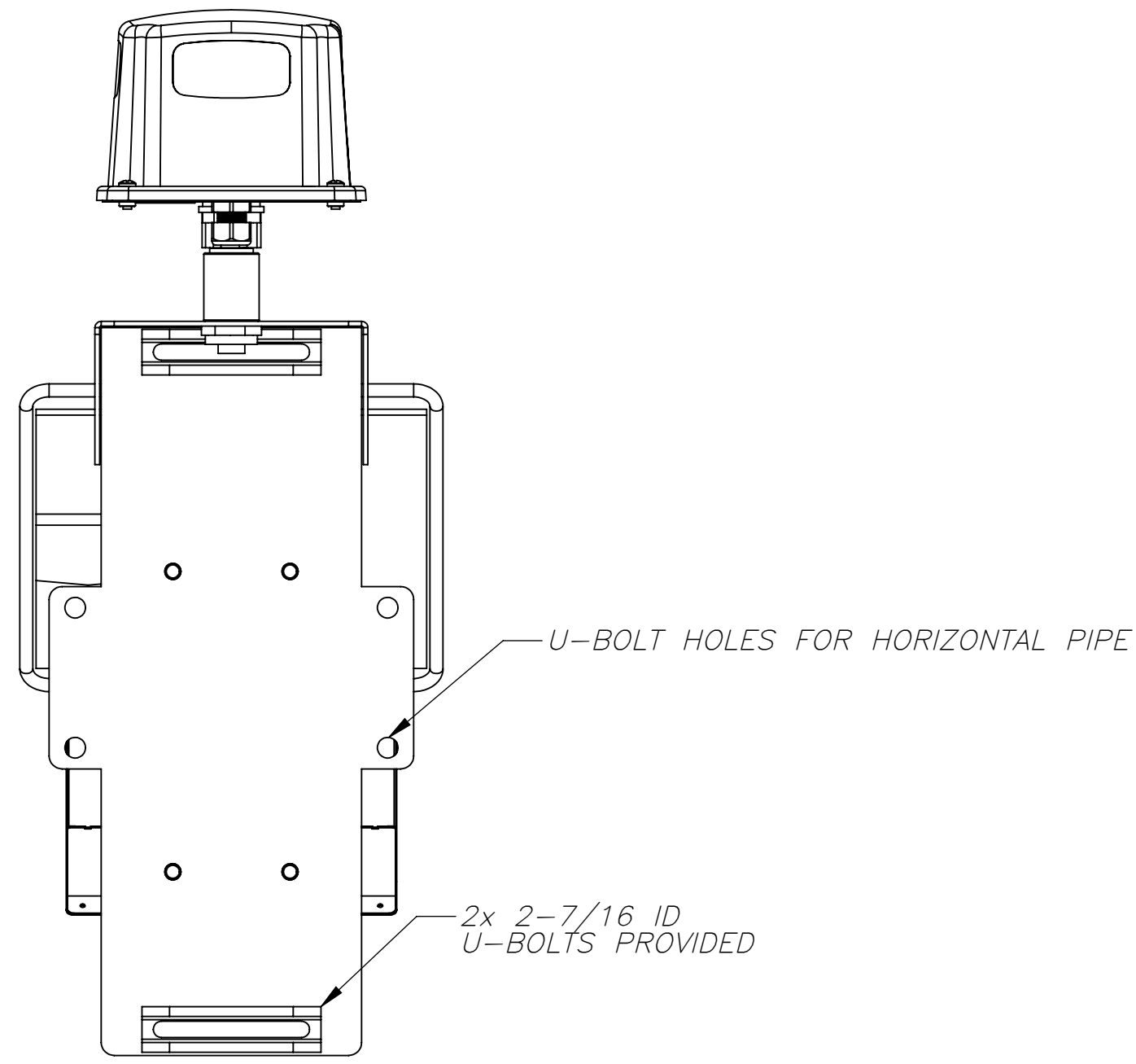
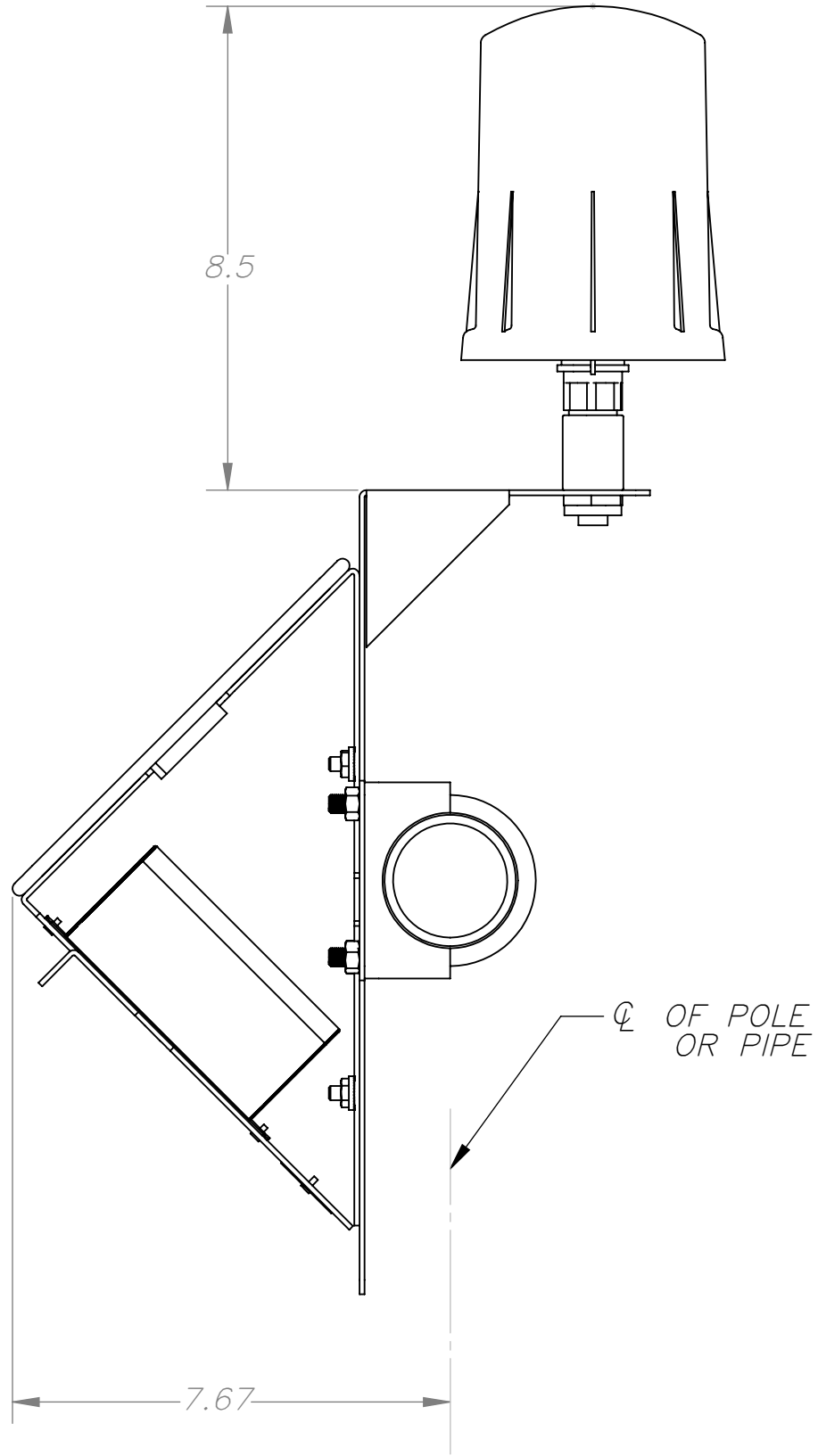
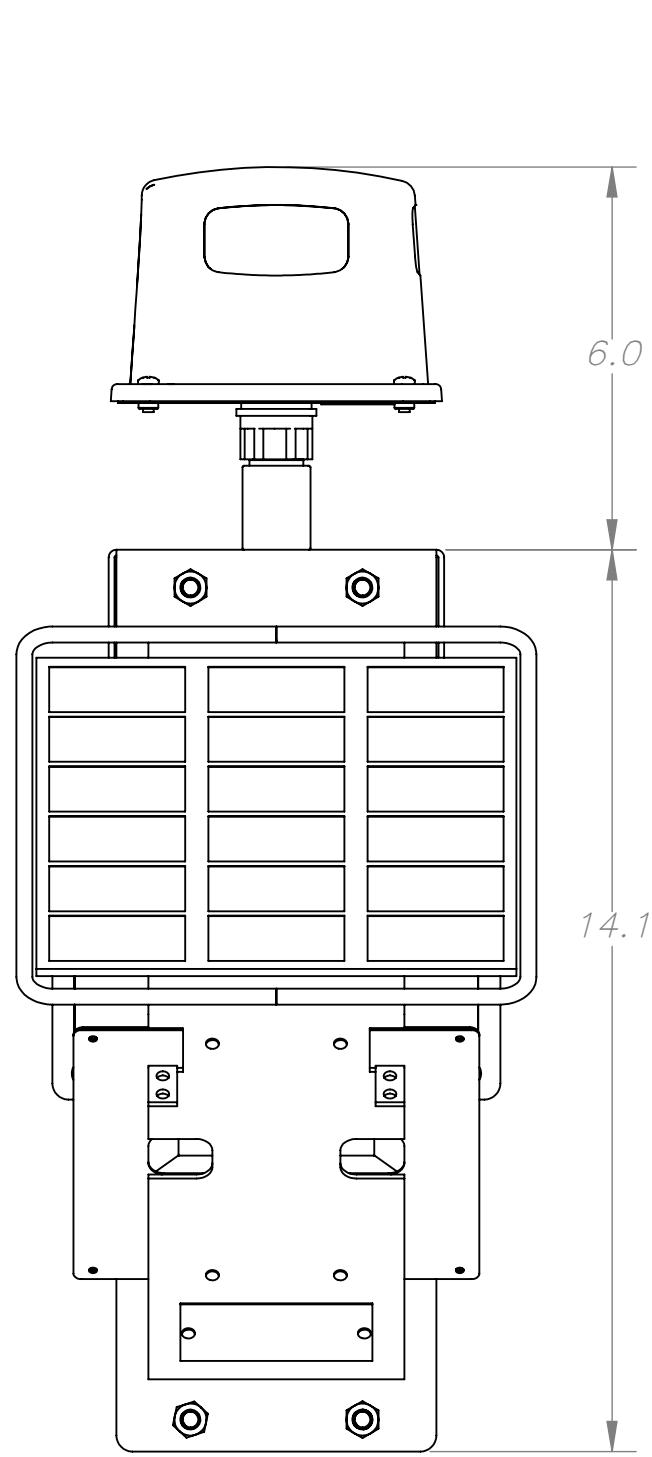

Order Code:
SentinelAccessory-BKT-Sentinel-Pole_MT

PROPRIETARY AND CONFIDENTIAL
THE INFORMATION CONTAINED IN THIS DRAWING IS THE SOLE PROPERTY OF SIGNALFIRE TELEMETRY. ANY REPRODUCTION IN PART OR AS A WHOLE WITHOUT THE WRITTEN PERMISSION OF SIGNALFIRE TELEMETRY IS PROHIBITED.

UNLESS OTHERWISE SPECIFIED:		NAME	DATE
DIMENSIONS ARE IN INCHES		DRAWN	S. BLODGETT 4/26/21
TOLERANCES:		CHECKED	S. KELLER xx/xx/xx
FRACTIONAL ± 1/64		ENG APPR.	S. KELLER xx/xx/xx
ANGULAR: MACH ± 1/2°		MFG APPR.	S. KELLER xx/xx/xx
TWO PLACE DECIMAL ± .01		Q.A.	S. KELLER xx/xx/xx
THREE PLACE DECIMAL ± .005		COMMENTS:	
INTERPRET GEOMETRIC TOLERANCING PER:			
MATERIAL			
FINISH			
NEXT ASSY	USED ON		
APPLICATION	DO NOT SCALE DRAWING		

SignalFire Telemetry		
TITLE: Pole Bracket KIT		
SIZE	DWG. NO.	REV
C	965-0004-01	C
SCALE: 1:3	WEIGHT:	SHEET 1 OF 1