

Interface Manual

DIN Mounted Gateway

SignalFire Part Numbers: GWDIN, GWDIN-ENET



The SignalFire DIN Gateway has the following features:

- RS485 connection to Modbus client device
- Optional Modbus-TCP Ethernet interface module
- Wide range DC power input. 6 to 36VDC
- Two open collector digital outputs
- DIN rail mount
- Collects and caches Modbus data from all SignalFire remote nodes
- Provides configuration and status registers for remote configuration and status monitoring
- RP-SMA antenna port for connection to external 900MHz antenna
- Stores up to 4700 register values from any combination of remote nodes
- Supports transparent Modbus mode
- Internal Remote Shut Down (RSD) logic control option
- Modbus register re-mapping
- Remote configuration of SignalFire devices through an Ethernet gateway connection
- Remote sensor configuration (PACTware and RadarMaster)
- Radio is FCC and IC approved
- AES 128bit Encryption

Table of Contents

2

SignalFire Part Numbers: GWDIN, GWDIN-ENET	1
SignalFire Part Numbers: GWDIN, GWDIN-ENET	1
Specifications	4
Connections and Components	5
DIN Gateway Connections	5
Optional Ethernet Gateway Connections	5
Status LEDs	6
Operation	6
Remote Modbus Sticks and Sentinel-Modbus (non-sleeping radio only) Nodes	6
Remote Modbus Stick Node Re-Scan	7
Setup	7
Encryption	9
Checking Remote Nodes	10
Remote Node Configuration	11
Firmware Upgrades	13
Rescue Gateway (ARM) Bootload	13
Remote Shutdown (RSD) and Local Digital Output Control	14
RSD Configuration	15
Source Value Section	15
Relay Control Logic Section	16
Destination RSD Stick Section	17
Relay Pulse	17
Example	18
RSD Event log	18
Options	19
Local Digital Output	19
Modbus Register Remapping	20
Use Data Type Floats	21
Fail Mode	22
Load/Save Files	22
Import/Export CSV Files	22
Output Modules	23

RS485 Details	23
Network Map	23
Gateway Event Log	24
Saving the Gateway Log	24
Modbus Gateway Register Map	25
Coils	25
Holding Registers	26
Revision History	31
Hazardous Location Certification	32

Specifications

4

Enclosure Size	4.50" tall × 4.00" wide × 0.93" deep
Weight	0.3 lbs. (0.14kg)
Power Source	6-36VDC external power source
Operating Current	25mA average current @ 12VDC
Digital Outputs (2)	Open collector, 1A, 30V max
Temperature Rating	-40°C to +85°C
Radio	902-928MHz ISM Band, FHSS radio, 500mW, RP-SMA connector. FCC ID: W8V-GWDIN, IC: 8373A-GWDIN
Compliance	Certified for use in Class I, Division 2 groups C, D, T5. EXi [EXi] FCC/IC Certified. Certified to CSA C22.2 2015 No. 213. Conforms to ISA 12.12.01 2015.



WARNING: Use of this equipment in a manner not specified by the manufacturer may impair the protection provided by the equipment.



WARNING: The use of any parts not supplied by the manufacturer violates the safety rating of the equipment.

DIN Gateway Connections

The DIN Gateway has a 6-position pluggable terminal block for power and serial communications. The connections are as follows:

Terminal Name	Connection
6-36VDC (RED)	Positive Power (6 to 36 VDC)
GROUND (BLK)	Ground
RS232 TX (ORG)	RS-232 Debug TX, 9600 Baud (Only used with Ethernet Interface module)
RS232 RX (YEL)	RS-232 Debug RX, 9600 Baud (Only used with Ethernet Interface module)
MODBUS A (GRN)	RS-485 "A", 9600 Baud
MODBUS B (BRN)	RS-485 "B", 9600 Baud

In addition, a RS232 DB9 port is available for connection to the SignalFire Toolkit for configuration and diagnostics.

Gateway Hardware revision 2 also has a 3-position pluggable terminal block with two open collector digital outputs for signaling or alarm functions. Each output is rated to 30VDC and 1 Amp.

Optional Ethernet Gateway Connections

When used with a SignalFire Ethernet Interface Module, the 6-position screw terminal block should be connected to the color coded "Gateway Stick Connection" connector on the Ethernet Interface Module. Power can be supplied either to the Power Input terminals on the Ethernet Interface Module or via power over Ethernet (PoE). For more information on configuring and using the Ethernet Interface Module, please consult the Ethernet Interface Module manual.

NOTE: when used with an Ethernet Interface Module the DB9 on the Ethernet module must be used for ToolKit access.

Status LEDs

The DIN Gateway has three LED Available for field diagnostics. The RS485 TX/RX LEDs will blink in response to RS485 traffic, the status LED is described below.

STATUS LED	Description
Slow Flash (3 second pause)	System is running and in communication with radio network
Fast Flash (0.5 second pause)	System is running but no network found
Solid On	System Fault needs service or rescue bootloader

Operation

The DIN Gateway supports all remote SignalFire nodes making all remote sensor data available in Modbus format.

The register data from remote sensor nodes is available by requesting the remote node's Modbus ID and register address from that node's register map. The gateway will respond with the most recent copy of the data from the remote node. The gateway will automatically time-out data from a remote node it stops receiving data for.

If the remote node is a Modbus-Stick additional features are supported.

Remote Modbus Sticks and Sentinel-Modbus (non-sleeping radio only) Nodes

Remote nodes that have been pre-configured forward their set of registers to the Modbus gateway on a pre-defined schedule (1 minute to 5 minutes is typical). The register data is then buffered in the gateway and is available to be read by the RTU at any time.

If a Modbus request is received by the gateway for a Modbus ID and address for which buffered data does not exist, but the Modbus ID is known, the Modbus request will be forwarded to the remote Modbus node over the SignalFire network. The response is returned to the RTU.

If a request for multiple registers is issued by the RTU, and if the gateway does not have all registered data buffered, an exception will be returned. The system will not combine buffered and transparent data within a single Modbus response.

Remote Modbus Stick Node Re-Scan

It is possible to cause a remote Modbus Stick to re-scan for attached Modbus devices by writing to one of the gateway's configuration registers. This is useful to discover a Modbus device that is added to an existing Modbus node. The scan may be initiated by one of the two methods. First, if the radio address of the Modbus Stick is known, writing this address to gateway register 3000 will result in a scan. Second, if the Modbus ID of one of the already registered devices attached to a Modbus Stick is known, a scan will be started by writing the ID to gateway register 3002.

Setup

The DIN Gateway requires an initial configuration over RS-232 using the SignalFire Toolkit. Connect a USB-Serial cable (can be purchased from SignalFire) between a computer and the Gateway's DB9 port.

The following items must be configured to set up a SignalFire network:

- Radio Network
- Radio Network Group
- Corporate ID/Encryption Key

NOTE: If used with an Ethernet Gateway module the DB9 on the Ethernet module must be used for ToolKit access.

Using the SignalFire Toolkit

The SignalFire Toolkit application can be downloaded at www.signal-fire.com/customer. After installation, launch the software and the main toolkit window will open:



Select the COM port associated with the DIN Gateway and click "Auto-Detect Device on COM Port." This will open the device configuration window, where all device settings can be configured.

If the Gateway is connected to an Ethernet Module, instead select the Modbus Gateway Stick in the dropdown menu of the main ToolKit window, and click "Open Device Window". In the upper left corner, check off the "TCP Connection" box, type in the IP Address, and click "Open". The port number (10002) will be automatically added, so this is not necessary to enter it.

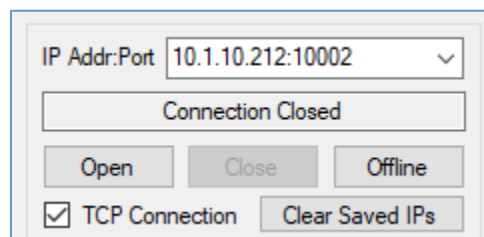

Network Setting

The network is set using the SignalFire Toolkit. There can only be one Gateway per network/group/encryption combination, otherwise they will conflict. In a system with multiple Gateways, each Gateway must be on a separate network/group/encryption combination. **The network, network group, and corporate ID/encryption key settings must match those of its nodes for them to communicate.**

Encryption

To protect your over-the-air data and prevent tampering, SignalFire networks starting with radio version 2.50 and Gateway version 7.93 come with encryption. Legacy products use a Corporate ID, but can be switched over to use an encryption key if the firmware and Toolkit are up to date.

To set up a legacy Gateway to use encryption, click the checkbox labeled **Enable Encryption** inside the **Set Corporate ID** box. All newer Gateways come with this option enabled with "signalfire" as the default encryption key.

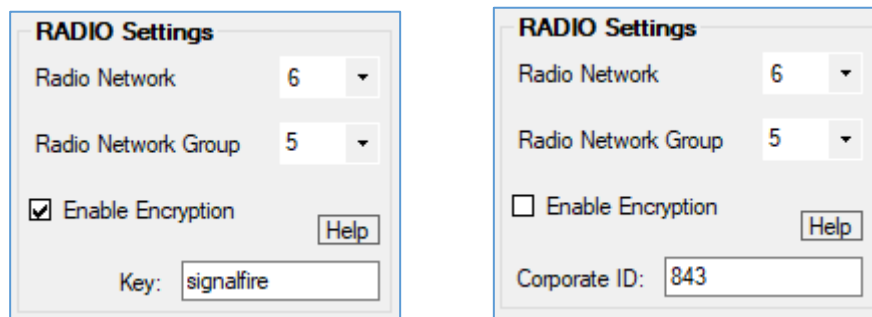

Radio settings box with and without encryption enabled. For more details, click the Help button.

The box will then change into a **Set Encryption Key** box, and it will prompt instead for the encryption key you would like to use. Note that keys may not contain spaces or angle brackets. Enter it and then press **Set**. If you are setting up a new network, you will need to set the encryption key on all of your devices. If you are swapping out the Gateway for a legacy network, you can simply uncheck Enable Encryption and set the Corporate ID, and it will remain compatible with the older system.

It is also possible to hide your encryption key so it cannot be read. This is the most secure option, but if you forget your key, there is no way to recover it – you must reset the key on every device on its network. To enable this option, select **Set Encryption Key Unrecoverable** under the **Settings** menu.

Checking Remote Nodes

10

If one or more remote nodes are configured with the correct network settings, they will send their data to the gateway. Clicking Refresh List will populate the list with all connected remote nodes. The gateway displays the node type, node name (if it has been set), RSSI signal strength, check-in interval, the Time-To-Live (TTL), and the node's radio and main firmware versions.

The RSSI and TTL values are color coded (Green, yellow, orange, red) to indicate relative link quality of a node. The 'TTL Current' indicates the number of minutes remaining until the node will be timed out of the gateway if no updates are received. The 'TTL Max' indicates the maximum TTL for that node and is equal to the node's check-in interval times 5 plus 2. The 'TTL Current' will reset to the 'TTL Max' each time an update is received from that node. The 'TTL Current' will decrement once a minute.

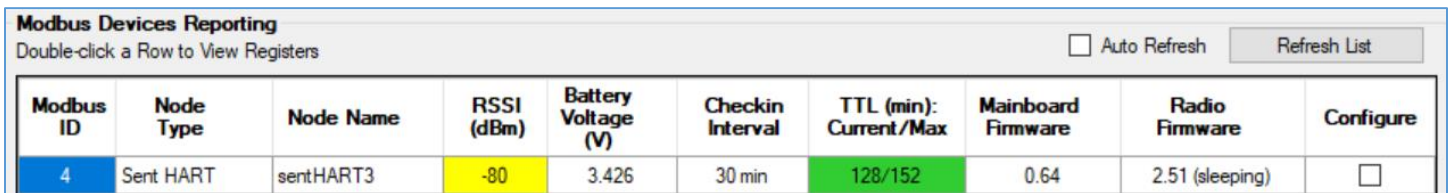

Modbus Devices Reporting
Double-click a Row to View Registers Auto Refresh Refresh List

Modbus ID	Node Type	Node Name	RSSI (dBm)	Battery Voltage (V)	Checkin Interval	TTL (min): Current/Max	Mainboard Firmware	Radio Firmware	Configure
4	Sent HART	sentHART3	-80	3.426	30 min	128/152	0.64	2.51 (sleeping)	<input type="checkbox"/>

Double clicking on one of the nodes in the list will bring up additional detail including the register data from the remote node.

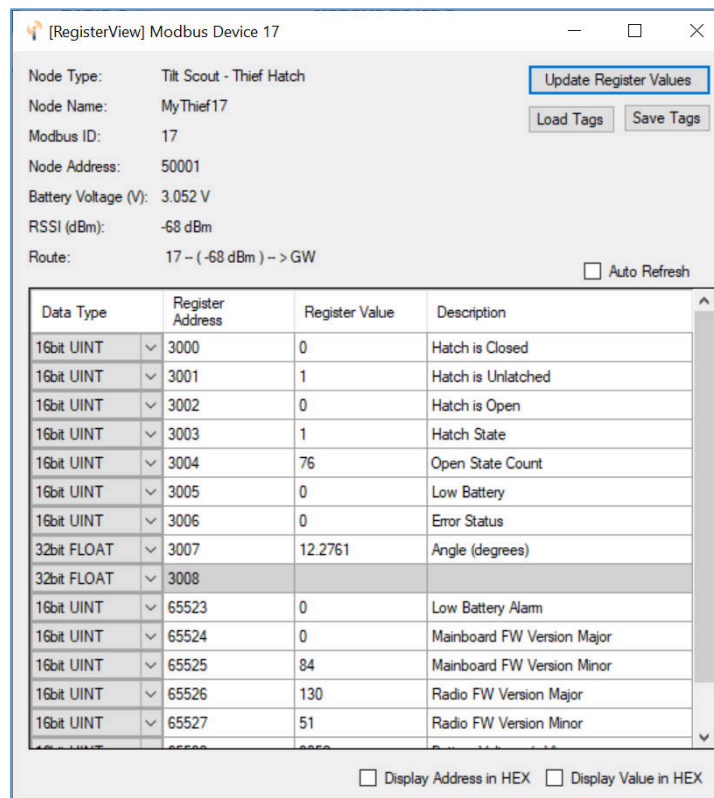

[RegisterView] Modbus Device 17

Node Type: Tilt Scout - Thief Hatch
Node Name: MyThief17
Modbus ID: 17
Node Address: 50001
Battery Voltage (V): 3.052 V
RSSI (dBm): -68 dBm
Route: 17 - (-68 dBm) -> GW

Auto Refresh

Data Type	Register Address	Register Value	Description
16bit UINT	3000	0	Hatch is Closed
16bit UINT	3001	1	Hatch is Unlatched
16bit UINT	3002	0	Hatch is Open
16bit UINT	3003	1	Hatch State
16bit UINT	3004	76	Open State Count
16bit UINT	3005	0	Low Battery
16bit UINT	3006	0	Error Status
32bit FLOAT	3007	12.2761	Angle (degrees)
32bit FLOAT	3008		
16bit UINT	65523	0	Low Battery Alarm
16bit UINT	65524	0	Mainboard FW Version Major
16bit UINT	65525	84	Mainboard FW Version Minor
16bit UINT	65526	130	Radio FW Version Major
16bit UINT	65527	51	Radio FW Version Minor

Display Address in HEX Display Value in HEX

Remote Node Configuration

11

The SignalFire Gateway allows configuration changes to be made to any of the connected SignalFire remote nodes wirelessly. To use this feature, access to the Gateway debug port is required. This may be accessed over a TCP/IP network using a SignalFire Ethernet Gateway module, or by a direct connection to the Gateway RS232 port.

To start a remote configuration session with a remote node, select the check-box next to the node to configure.

The screenshot shows the Modbus Gateway software interface. At the top, there is a menu bar with 'File', 'Options', 'Settings', 'Updates', 'Tools', and 'Help'. Below the menu bar, there is a section for 'Modbus Devices Reporting' which includes a table of connected devices. The table has columns for Modbus ID, Node Type, Node Name, RSSI (dBm), Battery Voltage (V), Checkin Interval, TTL (min): Current/Max, Mainboard Firmware, Radio Firmware, and a Configure checkbox. The device with Modbus ID 20, 'Scout Press' (PScout20), has its 'Configure' checkbox checked. Below the table, there are sections for 'RADIO Settings', 'MODBUS RS485 Settings', and 'Remote Configuration'. The 'Remote Configuration' section shows a green progress bar and a 'Modbus Device is Ready' message, with 'Configure' and 'End' buttons.

Modbus ID	Node Type	Node Name	RSSI (dBm)	Battery Voltage (V)	Checkin Interval	TTL (min): Current/Max	Mainboard Firmware	Radio Firmware	Configure
3	Flow Totalizer V2	Turbine	-48	3.288	1 min	6/7	1.09	2.51 (sleeping)	<input type="checkbox"/>
5	Scout Tilt TH	HATCH	-68	3.421	10 min	42/52	0.84	2.51 (sleeping)	<input type="checkbox"/>
7	Sent Dig	Discrete	-56	4.631	1 min	6/7	0.59	2.51 (sleeping)	<input type="checkbox"/>
10	RSD Stick	RSD_Stick	-61	12.117	1 min	7/7	0.75	2.50	<input type="checkbox"/>
11	MB Mirror	Esther	-74	11.585	1 min	6/7	0.81	2.50	<input type="checkbox"/>
20	Scout Press	PScout20	-57	3.326	30 sec	3/4	0.90	2.51 (sleeping)	<input checked="" type="checkbox"/>
30	Sent MB 2DI	Electrolab	-57	3.442	30 sec	3/4	0.59	2.51 (sleeping)	<input type="checkbox"/>
31	Scout Link	CERABARS	-49	3.372	15 sec	3/3	0.02	2.51 (sleeping)	<input type="checkbox"/>
90	WIOM	WIOM	-59	11.783	1 min	7/7	0.21	2.50	<input type="checkbox"/>
100	Sent HART	Vega81	-55	4.631	15 sec	3/3	0.64	2.51	<input type="checkbox"/>
101	Sent HART	Rose5300	-39	4.665	15 sec	3/3	0.64	2.51 (sleeping)	<input type="checkbox"/>

If the device has a non-sleeping radio the remote configuration session will be ready immediately. If it is a sleeping device, you must wait for the node to either check-in or send a "beacon" so that it can be commanded into configuration mode. The Sentinel nodes send a beacon every two and a half minutes, while all other sleeping nodes send a beacon every five and a half minutes. When the device has entered a remote configuration session you will see a message indicating the device is ready. Click **Configure** to open the configuration window (image on next page).

Make any necessary changes and click the **Apply All Settings** button to save the changes. When finished with the configuration, close the configuration window and then click the **End** button in the Gateway window to end the session. The session will also automatically time-out after 15 minutes of inactivity and the Node will resume normal operation.

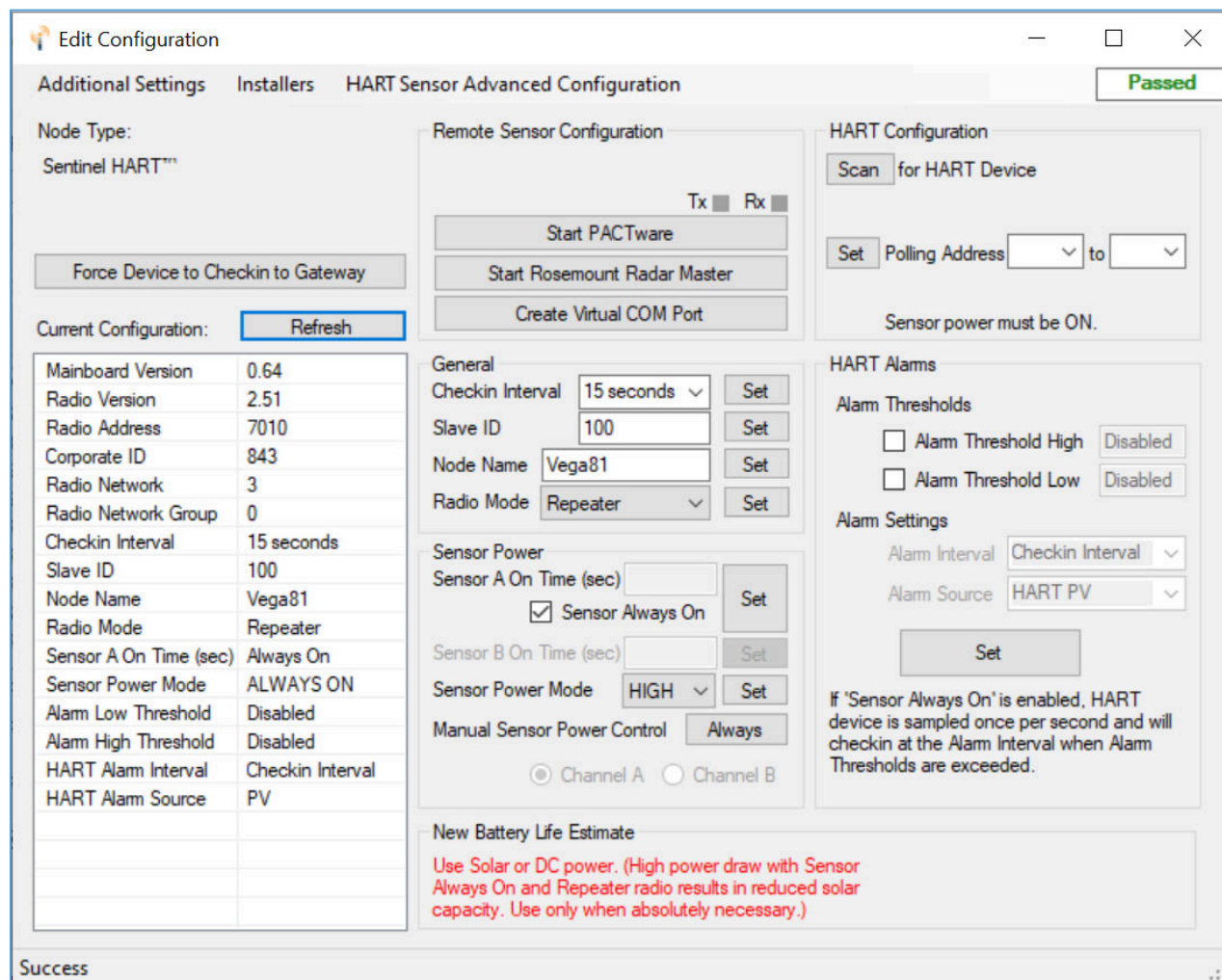

Example Remote Configuration Window

Further information on how to remotely configure a HART device through the ToolKit using PACTware can be found in the "Remote HART Sensor Configuration Manual".

Firmware Upgrades

13

Firmware updates for both the gateway (ARM) and the built-in radio are possible over the RS-232 debug interface using the SignalFire Toolkit, or over a remote TCP connection if an Ethernet Gateway module is used.

Gateway (ARM) Firmware update steps

- 1 Open the SignalFire Toolkit application.
- 2 Open the correct COM port connected to the RS-232 port of the gateway.
- 3 Go to the **Update** menu and select **Update Gateway Firmware**.
- 4 The latest gateway firmware file will be selected by default.
- 5 Click **Start Upgrade**.

Gateway Radio Firmware update steps:

- 1 Open the SignalFire Toolkit application.
- 2 Open the correct COM port connected to the RS-232 port of the gateway.
- 3 Go to the **Update** menu and select **Update Radio Firmware**.
- 4 The latest radio firmware file will be selected by default.
- 5 Click **Start Upgrade**.

Rescue Gateway (ARM) Bootload

If in the process of a firmware update there is a power failure or other communications failure it may be necessary to do a "rescue bootloader." If the base LED is solid on and/or the Toolkit is unable to communicate with the Gateway the following process is necessary.

- 1 Remove DC power to the Gateway.
- 2 Open the SignalFire Toolkit application.
- 3 Open the correct COM port connected to the RS-232 port of the gateway.
- 4 Go to the **Update** menu and select **Update Gateway Firmware**.
- 5 The latest gateway firmware file will be selectable by default.
- 6 Click **Start Upgrade**.
- 7 Now re-connect the DC power to the gateway. The firmware update process should start. If the firmware update does not start remove power for at least 10 seconds and re-try.

Remote Shutdown (RSD) and Local Digital Output Control

The SignalFire Gateway supports **Internal Logic Control** capability which enables the Gateway to control output relays on SignalFire RSD sticks as well as the two digital outputs local to the Gateway.

The SignalFire Gateway Stick receives data from multiple remote nodes. It can use the data from those remote nodes to set the relay output on one or more remote RSD sticks. An example of the topology is shown in the following figure:

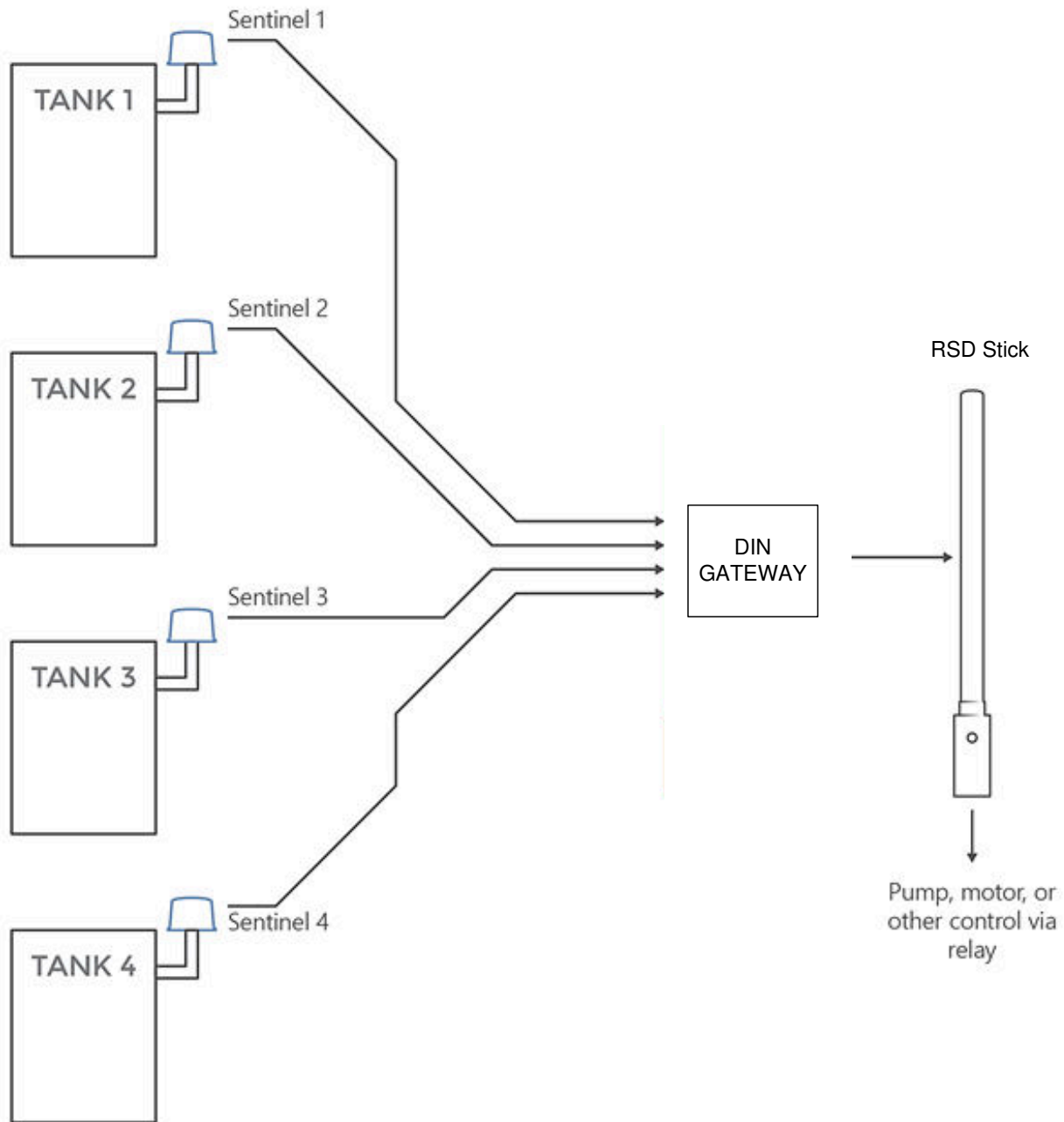

RSD Configuration

15

From the Gateway configuration window within the SignalFire Toolkit, go to the **Settings** menu and select **Remote Shutdown Settings**. This will open the RSD configuration window.

Source Value Section

The 'Source Value' section is used to select the source register for the logic rule.

Source Value				
Modbus ID	Node Type	Register Address	Register Type	Current Register Value
15	Sentinel HART™	4005-HART PV	32bit FLOAT	Unknown
0	None	0	16bit UINT	Unknown
0	None	0	16bit UINT	Unknown
0	None	0	16bit UINT	Unknown
0	None	0	16bit UINT	Unknown
0	None	0	16bit UINT	Unknown
0	None	0	16bit UINT	Unknown
0	None	0	16bit UINT	Unknown
0	None	0	16bit UINT	Unknown
0	None	0	16bit UINT	Unknown
0	None	0	16bit UINT	Unknown

Modbus ID – The Modbus ID of the remote source node.

Node Type – Drop-down list of standard SignalFire remote nodes. Select the type of remote node here, or select **Custom** for manual data entry.

Register Address – Select the register address for the data to use for the logic, or manually enter the register address if **Custom** was select for the node type.

Register Type – The correct register data type will automatically be selected unless **Custom** is used. If using a custom register address, select the correct data type here.

Current Register Value – Displays the value of the selected source data register. Clicking the **Update** button will refresh this value.

The 'Relay Control Logic' section is used to set the trigger thresholds for the selected source data register.

Relay Control Logic					
Run System (Energize Relay) when...	Value	System (De-energize Relay) when...	Value	Number of Readings	
Greater than	14	Less than	10	3	▼
Greater than	0	Less than	0	1	▼
Greater than	0	Less than	0	1	▼
Greater than	0	Less than	0	1	▼
Greater than	0	Less than	0	1	▼
Greater than	0	Less than	0	1	▼
Greater than	0	Less than	0	1	▼
Greater than	0	Less than	0	1	▼
Greater than	0	Less than	0	1	▼
Greater than	0	Less than	0	1	▼
Greater than	0	Less than	0	1	▼

Run System (Energize Relay) – Select the logic operand to use for the “energize” logic evaluation.

Value – The value that the relay will be energized. Note that the energized state is the normal “operating” state of the relay.

Shutdown System (De-Energize Relay) – The logic operand to use for the “de-energize” logic evaluation. This will automatically be the opposite of the selection for the energize case. Note that the de-energized state is the SAFE state of the relay.

Value – The value that the relay will be de-energized. Note that the de-energize state is the “safe” state of the relay.

Number of Readings – This field contains the number of check-in packets that must be received in a row that are above (or below) the logic threshold for the de-energize condition. This is useful so that a single (possibly a glitch) reading does not cause a shut-down. The default is 1 where each check-in will cause the rule to be evaluated and acted on. A single reading that satisfies the run system (energize) condition will cause the relay to energize.

Destination Relay		
Modbus ID	Relay Channel	Current Relay State (readonly)
10	1	De-energized
0	1	Unknown
0	1	Unknown
0	1	Unknown
0	1	Unknown
0	1	Unknown
0	1	Unknown
0	1	Unknown
0	1	Unknown
0	1	Unknown
0	1	Unknown

Modbus ID – The Modbus ID of the destination RSD Stick, or the Modbus ID of the Gateway (default 247) for the local digital outputs.

Relay Channel – Select the relay or digital output channel to switch

Current Relay State – Shows the last value of the relay or digital output as reported to the gateway. Clicking the Update button will refresh this value.

After filling out the table click **Write Remote Shutdown Settings to Gateway** to store the setting in the gateway Stick.

Relay Pulse

Starting with ToolKit version 2.2.3, and Gateway Firmware version 8.22, destination relays can be configured to pulse instead of being permanently energized or de-energized. To do so, in the **Relay Channel** drop-down menu, select the same relay but in "(Pulse)" mode. Specify whether to pulse during run or shutdown, and specify the pulse duration.

Destination Relay			Relay Pulse	
Modbus ID	Relay Channel	Current Relay State (readonly)	Pulse Relay on...	Pulse Time (sec)
10	1 (Pulse)	De-energized	Run	3

Example

Line 1 has been configured with a source data node as a Sentinel-Analog with the loop current (in μA) as the selected register. The relay will energize when the loop current is above $1400\mu\text{A}$ (14mA) and de-energize when the loop current is below $1300\mu\text{A}$ (13mA). Note that this configuration has a $1000\mu\text{A}$ (1mA) hysteresis factor.

Source Node					Relay Control Logic					Destination Counter Stick		
Modbus ID	Node Type	Register Address	Register Type	Current Register Value	Energize Relay when...	Value	De-energize Relay when...	Value	Number of Readings	Modbus ID	Relay Channel	Current Relay State (readonly)
1	Sentinel Analog	3001-Current(μA)	16bit UINT	14495	Greater than	14000	Less than	13000	1	5	1	Energized
2	A2 Analog	1003-Digital In	BOOLEAN	1	Equal to	1	Equal to	0	1	5	1	Energized
3	Sentinel HART	4005-HART PV	32bit FLOAT	8.22507	Greater than	3.15	Less than	3.05	1	5	1	Energized
4	Sentinel Digital	3012-Digital In 1	BOOLEAN	0	Equal to	0	Equal to	1	1	5	1	Energized
5	None	0	16bit UINT	Unknown	Greater than	0	Less than	0	1	0	1	Unknown
6	None	0	16bit UINT	Unknown	Greater than	0	Less than	0	1	0	1	Unknown
7	None	0	16bit UINT	Unknown	Greater than	0	Less than	0	1	0	1	Unknown
8	None	0	16bit UINT	Unknown	Greater than	0	Less than	0	1	0	1	Unknown
9	None	0	16bit UINT	Unknown	Greater than	0	Less than	0	1	0	1	Unknown
10	None	0	16bit UINT	Unknown	Greater than	0	Less than	0	1	0	1	Unknown
11	None	0	16bit UINT	Unknown	Greater than	0	Less than	0	1	0	1	Unknown
12	None	0	16bit UINT	Unknown	Greater than	0	Less than	0	1	0	1	Unknown

In this example all 4 source nodes are assigned to the same destination Modbus ID and relay channel so the following statement applies:

If more than one rule is assigned to the same destination RSD Stick (or gateway output) and relay channel, then all the rules must meet the energize condition for the remote relay to be energized. In other words, the RSD table logic is a Boolean AND.

Alternatively, this means that if any one of the four source node's logic results in the "de-energize" condition being true the relay will be de-energized (safe).

RSD Event log

The RSD events will be stored in the gateway internal event log which can be read using the ToolKit. Additionally, a basic RSD event log containing the last 5 RSD events is available to be read via Modbus from registers 7000-7024. See the Modbus register map for details. The Modbus event log is not maintained through gateway resets.

Options

There are two check boxes for additional logic options.

- Failsafe Enabled - Missing Slave or Register results in Relay being De-energized
- Latch De-energize - Requires RTU to Re-energize Relay via Modbus Coil Write

Failsafe Enabled – If this option is selected **all** rules must have valid data for the relay to be energized. If one or more of the nodes times-out or does not exist the relay will be de-energized.

If this option is not selected, then a node that is not installed or fails to check in will be ignored and the relay will be energized using logic only from the units that are active.

Latch De-Energized – If this option is selected the rules may only de-energize the relay. For the relay to be energized again a Modbus write from a PLC to the gateway for the destination RSD stick relay must occur. This is useful if manual intervention is required before the relay is energized after an event. In the example above, a Modbus coil write to Modbus ID 5 relay channel 1 (which is register 1) is required to energize the relay. See the RSD Stick manual for a detailed register map.

The “Normal” state of the relay or digital output is the un-energized state and this state should be used to set the controlled system (pump, motor,...) in the “safe” or “off” state.

Local Digital Output

The DIN Gateway has two local open connector outputs on the module, found on the underside. These can be controlled either like any other digital output using the RSD logic table seen above, by writing to registers on the Gateway (see register table on page 23), or manually in the Gateway itself by clicking on the **View Gateway Status Registers** at the bottom of the Gateway window.

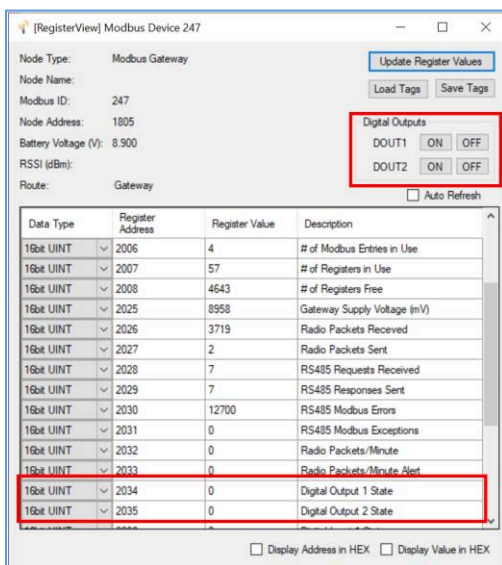

Modbus Register Remapping

The gateway allows any of the remote register data to be remapped to a single block of registers available at the Gateway's Modbus ID (default is 247). This is useful for collecting a subset of register data from multiple nodes and making it readable in a single block of registers. Up to 1500 registers can be remapped to the gateway's Modbus ID starting at register 5000.

To configure the remapping, first select **Modbus Register Remapping** from the **Settings** dropdown menu.

Remapped Address	Modbus ID	Register Address	Data Type	Node Name	Register Value	Description
5014	102	4009	32bit FLOAT	YokoEJA	20.01262	HART1:Tertiary Variable
5015	102	4010	32bit FLOAT	YokoEJA		
5016	102	4005	32bit FLOAT	YokoEJA	-0.1607956	HART1:Primary Variable
5017	102	4006	32bit FLOAT	YokoEJA		
5018			16bit UINT			
5019	30	65532	16bit UINT	Electrolab	3439	Battery Voltage (mV)
5020	30	65531	16bit INT	Electrolab	-30	RSSI (dBm)
5021	30	3990	16bit UINT	Electrolab	1727	
5022	30	3991	16bit UINT	Electrolab	1000	
5023	30	3996	16bit UINT	Electrolab	67	
5024	30	4006	16bit UINT	Electrolab	0	
5025	30	4005	16bit UINT	Electrolab	0	
5026	21	65532	16bit UINT		65535	Battery Voltage (mV)
5027	21	65531	16bit INT		-1	RSSI (dBm)
5028	5	65532	16bit UINT	HATCH	3423	Battery Voltage (mV)
5029	5	65531	16bit INT	HATCH	-66	RSSI (dBm)
5030	21	3002	16bit UINT		65535	
5031	21	3006	16bit UINT		65535	
5032	21	3008	16bit UINT		65535	
5033	21	3009	16bit UINT		65535	
5034	5	3003	16bit UINT	HATCH	1	Hatch State
5035	5	3007	32bit FLOAT	HATCH	5.621589	Angle (degrees)
5036	5	3008	32bit FLOAT	HATCH		
5037	5	65532	16bit UINT	HATCH	3423	Battery Voltage (mV)
5038	5	65531	16bit INT	HATCH	-66	RSSI (dBm)
5039			16bit UINT			
5040	20	3008	32bit FLOAT	PScout20	0	Sensor PSI (float)
5041	20	3009	32bit FLOAT	PScout20		

Remap Gateway Registers using Modbus ID 247

Enter the remote Modbus ID and register address to map to each gateway register and click **Write to GW** to remap the register(s).

The **Node Name**, **Data Type**, **Register Value**, and **Description** fields will automatically be filled in by the gateway once the mapping is written to the gateway.

Use Data Type Floats

The Gateway's Modbus Register Remapping provides an option to remap all registers to 32-bit floats. This allows the user to enter a register and its data type knowing that it will be read from the gateway via Modbus as two 16-bit registers.

To use the floating-point remapping, select the 'Use Data Type Float' check box in the lower right of the remap window. This will erase the current register remap in the Gateway; the user will be asked to confirm this action before proceeding.

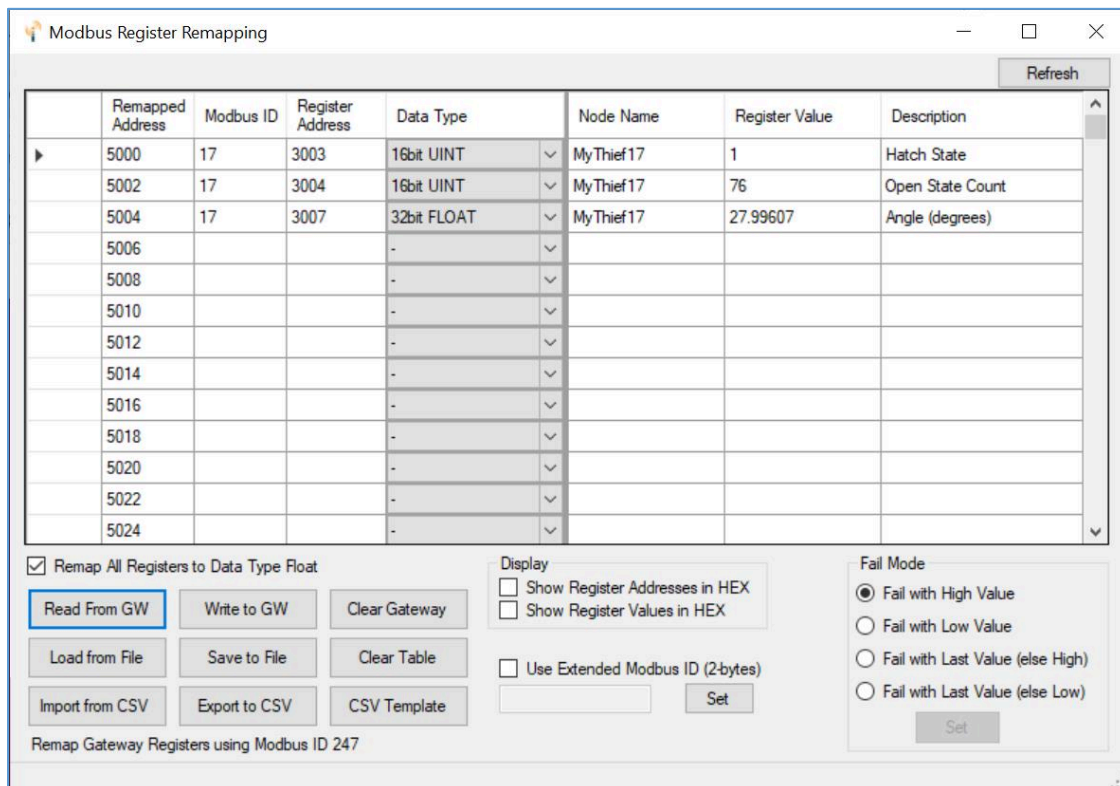

For each even numbered register address in the remap table, enter the Modbus ID, Register Address, and select the data type. The data types are provided in a pull-down list. Click the 'Write to GW' button to remap the register(s).

The **Node Name**, **Register Value**, and **Description** fields will automatically be filled in by the gateway once the mapping is written to the gateway.

Fail Mode

If the gateway does not have data for a remapped value it will respond with 0xFFFF, or 0x0000 for the register request, this is configurable globally with the Fail Mode settings.

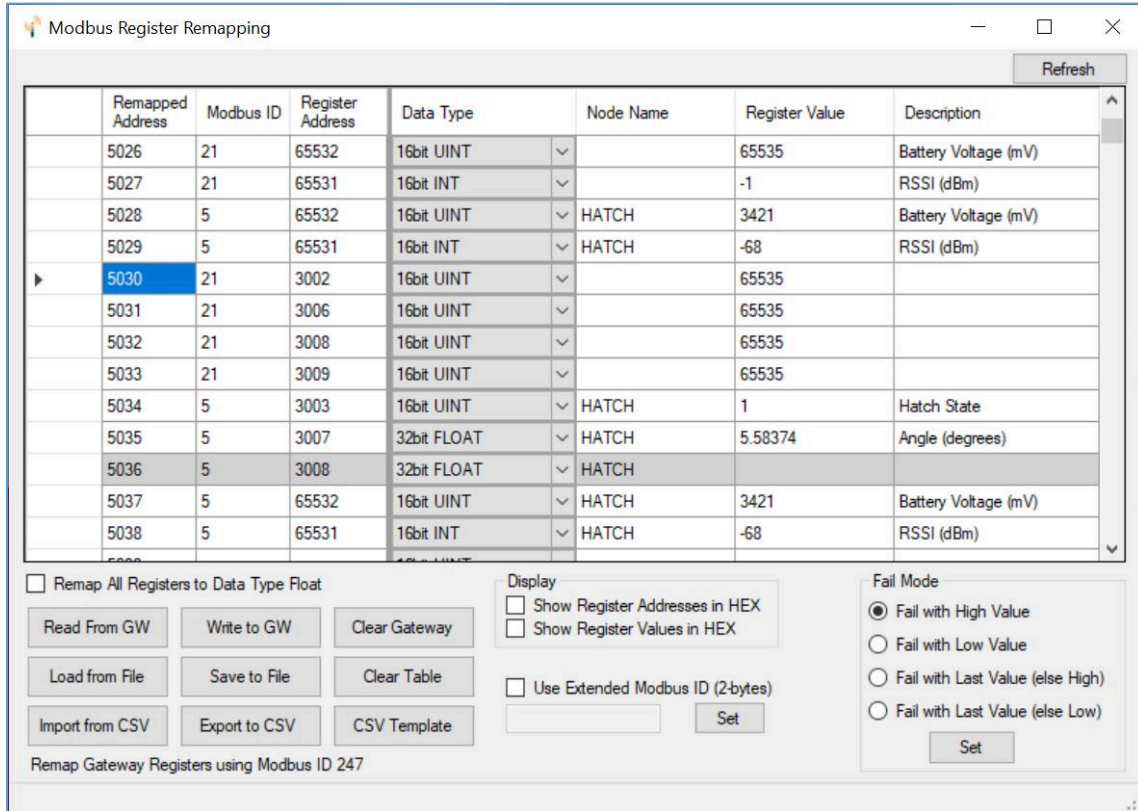

Modbus ID 21 isn't reporting in, fail mode set to "high"

Load/Save Files

The displayed remap information can be saved to a proprietary file by clicking the 'Save to File' button. The information may also be loaded from a '.remap' file by clicking the 'Load from File' button.

Import/Export CSV Files

To use 'csv' files, a specific format is required. Exporting the displayed remap information to a 'csv' file automatically writes the file in the required format. When creating a 'csv' file to import, it is recommended to start with the template provided by clicking the 'CSV Template' button.

If the 'Use Data Type Float' checkbox is checked, the pre-formatted template will include the exact strings required for the data type column for easy 'cut & paste' operations.

Output Modules

With the purchase of a SignalFire Analog Output Module or Digital Output Module, the Gateway can directly control analog (4-20mA, 1-5V) and digital outputs. The outputs for the module can be controlled through the “Analog/Relay Output Module” window under the Settings menu.

Further information on the modules can be found in their respective manuals.

RS485 Details

The Gateway keeps a log of any Modbus requests made to either itself or any Modbus nodes connected to it. The Modbus Transmission Log can be viewed under the Tools menu by selecting “RS485 Details”. The image below shows an example where an RTU polls a node for holding register 65532, battery voltage.

When the Gateway is open in the ToolKit, this log will be automatically written to the Log folder.

Network Map

The ToolKit comes with a graphical display of the network that includes the Gateway, its nodes, their Modbus IDs and signal strengths, and what path each node takes to communicate with the Gateway (such as hopping through a repeater stick).

Gateway Event Log

Starting with Gateway Firmware version 7.81 the Gateway keeps an internal log of events.

The event log can be viewed from the gateway window of the ToolKit by clicking 'View Gateway Log' at the bottom of the window. The gateway log events such as reboots, remote nodes joining/timing out, local RSD control events, remote configuration sessions, firmware updates, and more.

The Node Statistics tab shows information reported every four hours from Sentinels, Scouts, and Flow Totalizers to the Gateway with firmware versions from on or after September 21, 2020.

Saving the Gateway Log

Starting with ToolKit version 2.2.21.00, there is a 'Email Logs To Tech Support' button in the upper right hand corner. It will automatically save all the log entries and statistics, and open a window to email SignalFire support with the files attached using your default email client.

The screenshot shows the 'Gateway Log' window with three tabs: 'Gateway Log', 'Log Statistics', and 'Node Statistics'. The 'Node Statistics' tab is active, displaying a summary table of node statistics. Below the summary table is a 'DETAIL VIEW' section for Modbus ID 7, showing a detailed log of events with columns for Timestamp, Sequence #, Radio Address, Modbus ID, Battery Voltage (mV), Tx Count, Rx Count, Retry Count, Scan Tx Count, Scan Count, and Retry %.

Modbus ID	Node Type	Node Name	# Entries	Total Tx Count	Total Rx Count	Total Retry Count	Average Retry %
7	Sent Dig	Discrete	130	36548	5	5796	15
101	Sent HART	Rose5300	130	131790	3	13118	9
102	Sent HART	YokoEJA	120	112178	0	14898	13
30	Sent MB 2DI	Electrolab	128	128678	0	15508	12
100	Sent HART	Vega81	130	132949	2947	10810	8
20	Scout Press	PScout20	98	57114	7	10185	17
5	Scout Tilt TH	HATCH	117	3962	0	702	17

Timestamp	Sequence #	Radio Address	Modbus ID	Battery Voltage (mV)	Tx Count	Rx Count	Retry Count	Scan Tx Count	Scan Count	Retry %
5/31/2022 2:10:57 PM	23313	35248	7	4631	276	3	35	45	1	12
5/31/2022 10:10:13 AM	23306	35248	7	4632	297	0	61	0	0	20
5/31/2022 6:10:05 AM	23299	35248	7	4632	277	0	40	45	1	14
5/31/2022 2:09:59 AM	23292	35248	7	4631	272	0	34	44	1	12
5/30/2022 10:09:06 PM	23284	35248	7	4631	297	0	61	89	1	20
5/30/2022 6:08:34 PM	23277	35248	7	4632	264	0	27	0	0	10
5/30/2022 2:07:33 PM	23270	35248	7	4632	265	0	29	0	0	10

Modbus Gateway Register Map

25

The SignalFire Modbus Gateway by default is assigned Modbus ID number 247. **Only the Gateway status/configuration and remapped registers are read at this address.**

All remote node registers are read from the Modbus ID and register address of the remote node unless Modbus register remapping is used. If the gateway has a large total number of registers approaching 4700, register 2008 should be monitored to ensure that free registers are available before adding a new node.

Coils

Read coils with Modbus opcode 0x01 (Read Coil). Write coils with Modbus opcode 0x05 (Write Single Coil) or 0x15 (Write Multiple Coils).

Register Address	Register Number	Description	R/W
0000	00001	System Reset: Resets the gateway and radio	R/W
0001	00002	Radio Reset: Resets the radio leaving the gateway on	R/W
0002	00003	Counter Reset: Resets all GW status counters to zero (See Read Only Registers 2026-2031)	R/W
0101	00102	Analog/Relay Output Module 1 Relay 1	R/W
0102	00103	Analog/Relay Output Module 1 Relay 2	R/W
0103	00104	Analog/Relay Output Module 2 Relay 1	R/W
0104	00105	Analog/Relay Output Module 2 Relay 2	R/W
0131	00132	Digital Output Module 1 Relay 1	R/W
0132	00133	Digital Output Module 1 Relay 2	R/W
0133	00134	Digital Output Module 1 Relay 3	R/W
0134	00135	Digital Output Module 1 Relay 4	R/W
0135	00136	Digital Output Module 1 Relay 5	R/W
0136	00137	Digital Output Module 1 Relay 6	R/W
0137	00138	Digital Output Module 1 Relay 7	R/W
0138	00139	Digital Output Module 1 Relay 8	R/W
0139	00140	Digital Output Module 1 Relay 9	R/W
0140	00141	Digital Output Module 1 Relay 10	R/W
0141	00142	Digital Output Module 1 Relay 11	R/W
0142	00143	Digital Output Module 1 Relay 12	R/W
0143	00144	Digital Output Module 2 Relay 1	R/W
0144	00145	Digital Output Module 2 Relay 2	R/W
0145	00146	Digital Output Module 2 Relay 3	R/W
0146	00147	Digital Output Module 2 Relay 4	R/W
0147	00148	Digital Output Module 2 Relay 5	R/W
0148	00149	Digital Output Module 2 Relay 6	R/W
0149	00150	Digital Output Module 2 Relay 7	R/W
0150	00151	Digital Output Module 2 Relay 8	R/W

Register Address	Register Number	Description	R/W
0151	00152	Digital Output Module 2 Relay 9	R/W
0152	00153	Digital Output Module 2 Relay 10	R/W
0153	00154	Digital Output Module 2 Relay 11	R/W
0154	00155	Digital Output Module 2 Relay 12	R/W
2034	02035	State of Digital Output 1 (0=open, 1=closed)	R/W
2035	02036	State of Digital Output (0=open, 1=closed)	R/W
7100	07101	RSD Force Shutdown	R/W

Holding Registers

Read holding registers with Modbus opcode 0x03 (Read Holding Registers) or 0x04 (Read Input Registers). Write holding registers with Modbus opcode 0x06 (Write Single Register) or 0x16 (Write Multiple Registers).

Register Address	Register Number	Description	R/W
1000	41001	System Reset: Resets the gateway and radio	R/W
1001	41002	Radio Reset: Resets the radio leaving the gateway on	R/W
1002	41003	Counter Reset: Resets all GW status counters to zero (See Read Only Registers 2026-2031)	R/W
1003	41004	Radio Network	R
1004	41005	Radio Network Group	R
1005	41006	Radio Corporate ID	R
1101	41102	Analog/Relay Output Module 1 Relay 1	R/W
1102	41103	Analog/Relay Output Module 1 Relay 2	R/W
1103	41104	Analog/Relay Output Module 2 Relay 1	R/W
1104	41105	Analog/Relay Output Module 2 Relay 2	R/W
1119	41120	DIN GW Digital Output 1 Pulse (Seconds to pulse output on)	W
1120	41121	DIN GW Digital Output 2 Pulse (Seconds to pulse output on)	W
1121	41122	Analog/Relay Output Module 1 Relay 1 Pulse (Seconds to pulse relay on)	W
1122	41123	Analog/Relay Output Module 1 Relay 2 Pulse (Seconds to pulse relay on)	W
1123	41124	Analog/Relay Output Module 2 Relay 1 Pulse (Seconds to pulse relay on)	W
1124	41125	Analog/Relay Output Module 2 Relay 2 Pulse (Seconds to pulse relay on)	W
1131	41132	Digital Output Module 1 Relay 1	R/W

Register Address	Register Number	Description	R/W
1132	41133	Digital Output Module 1 Relay 2	R/W
1133	41134	Digital Output Module 1 Relay 3	R/W
1134	41135	Digital Output Module 1 Relay 4	R/W
1135	41136	Digital Output Module 1 Relay 5	R/W
1136	41137	Digital Output Module 1 Relay 6	R/W
1137	41138	Digital Output Module 1 Relay 7	R/W
1138	41139	Digital Output Module 1 Relay 8	R/W
1139	41140	Digital Output Module 1 Relay 9	R/W
1140	41141	Digital Output Module 1 Relay 10	R/W
1141	41142	Digital Output Module 1 Relay 11	R/W
1142	41143	Digital Output Module 1 Relay 12	R/W
1143	41144	Digital Output Module 2 Relay 1	R/W
1144	41145	Digital Output Module 2 Relay 2	R/W
1145	41146	Digital Output Module 2 Relay 3	R/W
1146	41147	Digital Output Module 2 Relay 4	R/W
1147	41148	Digital Output Module 2 Relay 5	R/W
1148	41149	Digital Output Module 2 Relay 6	R/W
1149	41150	Digital Output Module 2 Relay 7	R/W
1150	41151	Digital Output Module 2 Relay 8	R/W
1151	41152	Digital Output Module 2 Relay 9	R/W
1152	41153	Digital Output Module 2 Relay 10	R/W
1153	41154	Digital Output Module 2 Relay 11	R/W
1154	41155	Digital Output Module 2 Relay 12	R/W
2000	42001	Node Address: Upper 16 bits of SFTS GW node address (the radio ID)	R
2001	42002	Node Address: Lower 16 bits of SFTS GW node address (the radio ID)	R
2002	42003	Radio Version: Upper 16 bits of Radio Firmware version number	R
2003	42004	Radio Version: Lower 16 bits of Radio Firmware version number	R
2004	42005	Gateway Version: Upper 16 bits of gateway firmware version number	R
2005	42006	Gateway Version: Lower 16 bits of gateway firmware version number	R
2006	42007	Node Count: Number of Modbus nodes that data is cached for this gateway	R
2007	42008	Used Register: Total number of registers allocated to Modbus devices	R
2008	42009	Free Register: Total number of free registers available for Modbus devices	R
2009	42010	Modbus ID [15-0]: Bitmask for Modbus IDs 15-0 (LSB is 0)	R
2010	42011	Modbus ID [31-16]: Bitmask for Modbus IDs 31-16 (LSB is 16)	R
2011	42012	Modbus ID [47-32]: Bitmask for Modbus IDs 47-32 (LSB is 32)	R
2012	42013	Modbus ID [63-48]: Bitmask for Modbus IDs 63-48 (LSB is 48)	R
2013	42014	Modbus ID [79-64]: Bitmask for Modbus IDs 79-64 (LSB is 64)	R
2014	42015	Modbus ID [95-80]: Bitmask for Modbus IDs 95-80 (LSB is 80)	R

Register Address	Register Number	Description	R/W
2015	42016	Modbus ID [111-96]: Bitmask for Modbus IDs 111-96 (LSB is 96)	R
2016	42017	Modbus ID [127-112]: Bitmask for Modbus IDs 127-112 (LSB is 112)	R
2017	42018	Modbus ID [143-128]: Bitmask for Modbus IDs 143-128 (LSB is 128)	R
2018	42019	Modbus ID [159-144]: Bitmask for Modbus IDs 159-144 (LSB is 144)	R
2019	42020	Modbus ID [175-160]: Bitmask for Modbus IDs 175-160 (LSB is 160)	R
2020	42021	Modbus ID [191-176]: Bitmask for Modbus IDs 191-176 (LSB is 176)	R
2021	42022	Modbus ID [207-192]: Bitmask for Modbus IDs 207-192 (LSB is 192)	R
2022	42023	Modbus ID [223-208]: Bitmask for Modbus IDs 223-208 (LSB is 208)	R
2023	42024	Modbus ID [239-224]: Bitmask for Modbus IDs 239-224 (LSB is 224)	R
2024	42025	Modbus ID [255-240]: Bitmask for Modbus IDs 255-240 (LSB is 240)	R
2025	42026	Supply Voltage: Gateway power supply voltage	R
2026	42027	Radio RX Count: Radio packets received count	R
2027	42028	Radio TX Count: Radio packets sent count	R
2028	42029	RS485RX Count: RS-485 messages received count	R
2029	42030	RS485TX Count: RS-485 messages sent count	R
2030	42031	RS485 Errors: Total Modbus errors from client and servers	R
2031	42032	Modbus Errors: Modbus exceptions from Modbus nodes	R
2032	42033	Radio packets received/transmitted per minute. (Recommended to be less than 60)	R
2033	42034	Radio packets per minute alert (0 if packets/min <= 60, 1 if packets/min > 60)	R
2034	42035	State of Digital Output 1 (0=open, 1=closed)	R/W
2035	42036	State of Digital Output 2 (0=open, 1=closed)	R/W
2041	42042	Seconds Since Power On (High Word)	R
2042	42043	Seconds Since Power On (Low Word)	R
2043	42044	Seconds Since Last Reboot (High Word)	R
2044	42045	Seconds Since Last Reboot (Low Word)	R
2100	42101	Address test register. Always returns 2100	R
2101	42102	Address test register. Always returns 2101	R
2102	42103	Address test register. Always returns 2102	R
3000	43001	Write the radio address of a Modbus Stick node to this register to cause that Modbus Stick to perform a scan for attached Modbus sensors (by node address).	W
3001	43002	Write the radio address of a Modbus Stick node to this register to cause that Modbus Stick to end a scan for attached Modbus sensors (by node address).	W
3002	43003	Write Modbus ID for a Modbus Client node to this register to cause that remote node to perform a scan for attached Modbus sensors (by Modbus ID).	W
3003	43004	Write Modbus ID for a Modbus Client node to this register to cause that remote node to end a scan for attached Modbus sensors (by Modbus ID).	W

Register Address	Register Number	Description	R/W
4001	44002	Status of Modbus ID 1: Returns 1 if device is present and 0 if not present	R
4002	44003	Status of Modbus ID 2: Returns 1 if device is present and 0 if not present	R
...	R
4240	44241	Status of Modbus ID 240: Returns 1 if device is present and 0 if not present	R
5000	45001	Remapped Register 1	R/W
5001	45002	Remapped Register 2	R/W
...	R/W
6499	46500	Remapped Register 1500	R/W
7000	47001	RSD Event 1 Line #	R
7001	47002	RSD Event 1 Source Modbus ID	R
7002	47003	RSD Event 1 Destination Modbus ID	R
7003	47004	RSD Event 1 Destination Relay Channel	R
7004	47005	RSD Event 1 Type (1 = Energize, 0 = De-Energize)	R
7005	47006	RSD Event 2 Line #	R
7006	47007	RSD Event 2 Source Modbus ID	R
7007	47008	RSD Event 2 Destination Modbus ID	R
7008	47009	RSD Event 2 Destination Relay Channel	R
7009	47010	RSD Event 2 Type	R
7010	47011	RSD Event 3 Line #	R
7011	47012	RSD Event 3 Source Modbus ID	R
7012	47013	RSD Event 3 Destination Modbus ID	R
7013	47014	RSD Event 3 Destination Relay Channel	R
7014	47015	RSD Event 3 Type	R
7015	47016	RSD Event 4 Line #	R
7016	47017	RSD Event 4 Source Modbus ID	R
7017	47018	RSD Event 4 Destination Modbus ID	R
7018	47019	RSD Event 4 Destination Relay Channel	R
7019	47020	RSD Event 4 Type	R
7020	47021	RSD Event 5 Line #	R
7021	47022	RSD Event 5 Source Modbus ID	R
7022	47023	RSD Event 5 Destination Modbus ID	R
7023	47024	RSD Event 5 Destination Relay Channel	R
7024	47025	RSD Event 5 Type	R
7100	47101	RSD Force Shutdown (1=force all RSD relays off, 0=run RSD logic)	R/W
7101	47102	Scratch Pad Register, can be used for RSD Control Logic	R/W

Register Address	Register Number	Description	R/W
7102	47103	Scratch Pad Register, can be used for RSD Control Logic	R/W
...	R/W
7132	47133	Scratch Pad Register, can be used for RSD Control Logic	R/W

Revision History

31

Revision	Date	Changes/Updates
1.0	10/02/15	Initial Release for DIN Gateway
1.1	2/26/16	Added FCC/IC certification details
1.2	4/6/16	Added detail for Gateway digital outputs
1.4/1.5	4/18/16	Updated IC statements and added C1D2 Statements
1.6	8/3/16	Added section on encryption
1.7/1.8	9/4/2018	Updated screenshots, rewrote network/encryption, cleaned up
1.9	10/17/2018	Added RSD pulse settings and registers
1.10	3/1/2019	Added section on digital outputs
1.11	4/9/20	Added Gateway Log support button, Digital Output Module
1.12	9/30/2020	Added Gateway log node statistics
1.13	3/15/21	Updated register map to include pulse output registers
1.14	8/4/2021	Updated register remap to 1500 registers
1.15	6/7/2022	Updated Modbus Gateway Register Map section

The DIN Gateway Module is rated Class 1 Division 2 non-Incendive.



WARNING: EXPLOSION HAZARD. DO NOT REMOVE OR REPLACE COMPONENTS UNLESS POWER HAS BEEN DISCONNECTED OR THE AREA IS FREE OF IGNITIBLE CONCENTRATIONS.

AVERTISSEMENT : RISQUE D'EXPLOSION . NE PAS RETIRER OU REMPLACER LES COMPOSANTS QUE L'ALIMENTATION EST DÉBRANCHÉ OU ZONE EST LIBRE DE CONCENTRATIONS IGNITIBLE.



WARNING – EXPLOSION HAZARD Substitution of components may impair suitability for Class I, Division 2

AVERTISSEMENT - RISQUE D'EXPLOSION. La substitution de composants peut rendre ce matériel inacceptable pour les emplacements de classe I, division 2



WARNING – EXPLOSION HAZARD Do not disconnect while circuit is live unless area is known to be nonhazardous

AVERTISSEMENT - RISQUE D'EXPLOSION. Ne débranchez pas lorsque le circuit est en direct , sauf si la zone est connue pour être nonhazardous



WARNING – The DIN Gateway must be installed in a suitable enclosure for intended environment

AVERTISSEMENT - Le passerelle DIN doit être installé dans une enceinte appropriée pour l'environnement prévu



WARNING – All wiring methods must be in accordance with the NEC

AVERTISSEMENT - Toutes les méthodes de Essorez doivent être en conformité avec la NEC

APPENDIX - FCC and IC Statements

Changes or modifications not expressly approved by SignalFire Telemetry, Inc could void the user's authority to operate the equipment.

This device complies with Part 15 of the FCC Rules. Operation is subject to the following two conditions:

(1) this device may not cause harmful interference, and (2) this device must accept any interference received, including interference that may cause undesired operation.

This equipment has been tested and found to comply with the limits for a Class B digital device, pursuant to Part 15 of the FCC Rules. These limits are designed to provide reasonable protection against harmful interference in a residential installation. This equipment generates, uses and can radiate radio frequency energy and, if not installed and used in accordance with the instructions, may cause harmful interference to radio communications. However, there is no guarantee that interference will not occur in a particular installation. If this equipment does cause harmful interference to radio or television reception, which can be determined by turning the equipment off and on, the user is encouraged to try to correct the interference by one of the following measures:

- Reorient or relocate the receiving antenna.
- Increase the separation between the equipment and receiver.
- Connect the equipment into an outlet on a circuit different from that to which the receiver is connected.
- Consult the dealer or an experienced radio/TV technician for help.

This device has been designed to operate with the antennas listed below, and having a maximum gain of 5.8 dBi. Antennas not included in this list or having a gain greater than 5.8 dBi are strictly prohibited for use with this device. The required antenna impedance is 50 ohms.

- San Jose Technology Inc. Model EEH-915
- Nearson Model: S467XX-915S

To reduce potential radio interference to other users, the antenna type and its gain should be so chosen that the equivalent isotropically radiated power (e.i.r.p.) is not more than that permitted for successful communication.

To comply with FCC's and IC's RF radiation exposure requirements, the antenna(s) used for this transmitter must be installed such that a minimum separation distance of 20cm is maintained between the radiator (antenna) & user's/nearby person's body at all times and must not be co-located or operating in conjunction with any other antenna or transmitter.

This device complies with Industry Canada's licence-exempt RSSs. Operation is subject to the following two conditions:(1) This device may not cause interference; and (2) This device must accept any interference, including interference that may cause undesired operation of the device.

Le présent appareil est conforme aux CNR d'Industrie Canada applicables aux appareils radio exempts de licence. L'exploitation est autorisée aux deux conditions suivantes : (1) l'appareil ne doit pas produire de brouillage, et (2) l'appareil doit accepter tout brouillage radioélectrique subi, même si le brouillage est susceptible d'en compromettre le fonctionnement.